

DIMENSIONI D'INGOMBRO - OVERALL DIMENSIONS

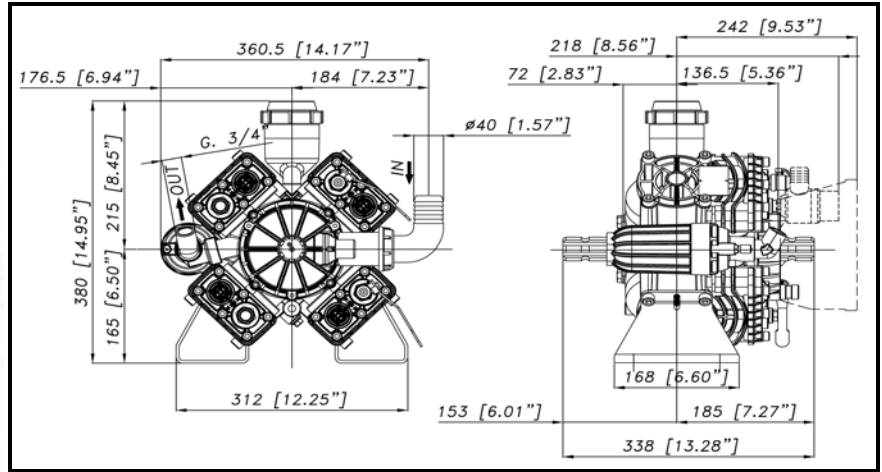

ALBERO POMPA - PUMP SHAFT

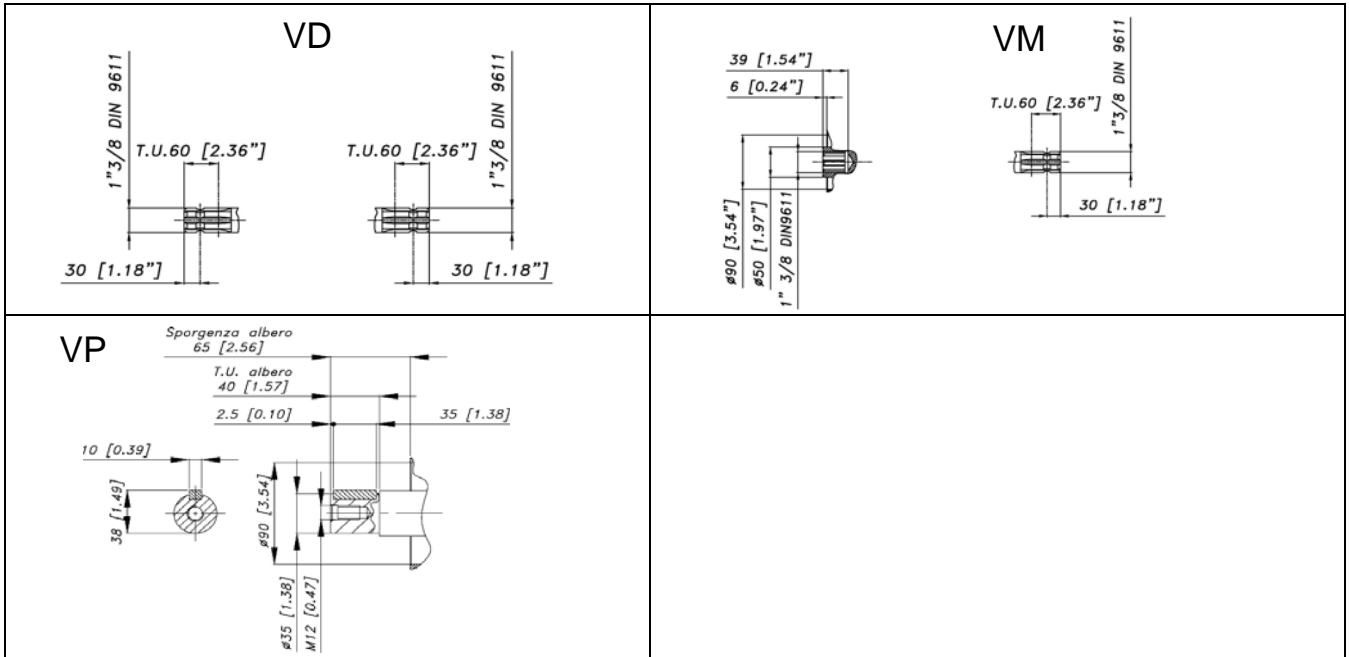

COPPIA DI SERRAGGIO - TORQUE CHART					
CODICE - CODE	Q.TY	POS	N-m	Lbr.ft	
86.3187.00.2	4	3	22	16,2	
86.4120.00.2	1	18	44	32,4	
86.2415.50.2	4	19	10	7,4	
86.1843.00.2	2	27	5	3,7	
86.3590.00.2	16	30	44	32,4	
23.0055.97.3	4	34	12	8,9	
86.1605.00.2	1	44	5	3,8	
			LOCTITE 542	LOCTITE 542	
86.2730.00.2	24	52	22	16,2	
86.2579.00.2	2	53	44	32,4	
86.2166.00.2	2	62	5	3,7	
85.2543.50.2	1	67	22	16,2	

Tolleranza di serraggio: 0/-10%  
Tolerance on torque value:

INFORMAZIONI UTILI USEFUL INFORMATION				
LUBRIFICANTE- LUBRICANT: OLIO MOTORE O SEMIIDRAULICO SAE 75-W90 MOTOR OIL OR SEMI-HYDRAULIC OIL SAE 75-W90				
PRESSIONE ACCUMULATORE ACCUMULATOR PRESSURE				
PRESSIONE DI LAVORO - OPERATING PRESSURE	2 ÷ 5	5÷10	10 ÷ 20	20 ÷ 50
ACCUMULATORE ACCUMULATOR	2	2 ÷ 5	5 ÷ 7	6 ÷ 8

KIT MEMBRANE - DIAPHRAGMS KIT

KIT	BUNA-N				DESMOPAN				VITON							PENTAX							
	36.9804.97.3	1	15	47	48	36.9805.97.3	1	15	47	48	36.9806.97.3	1	47	15	16	17	48	56	57	36.9808.97.3	1	15	47
POSIZIONE ESPLOSO POSITION NUMBER																							
QUANTITA' NEL KIT QUANTITIES INCLUDED	4	8	1	1	4	8	1	1	4	8	1	9	1	1	1	8	8	4	8	1	1	4	8

KIT POMPA/KIT VALVOLE - PUMP KIT/VALVES KIT

KIT	KIT POMPA VD-VP VD PUMP KIT								KIT POMPA VM							KIT VALVOLE VALVES KIT							
	36.9802.97.3	5	12	15	16	17	48	56	57	72	36.9809.97.3	42	42	42	42	42	42	42	42	36.9803.97.3	2	56	57
POSIZIONE ESPLOSO POSITION NUMBER																							
QUANTITA' NEL KIT QUANTITIES INCLUDED	1	1	9	1	1	1	8	8	1	1	1	1	1	1	1	1	1	1	8	8	8	8	8

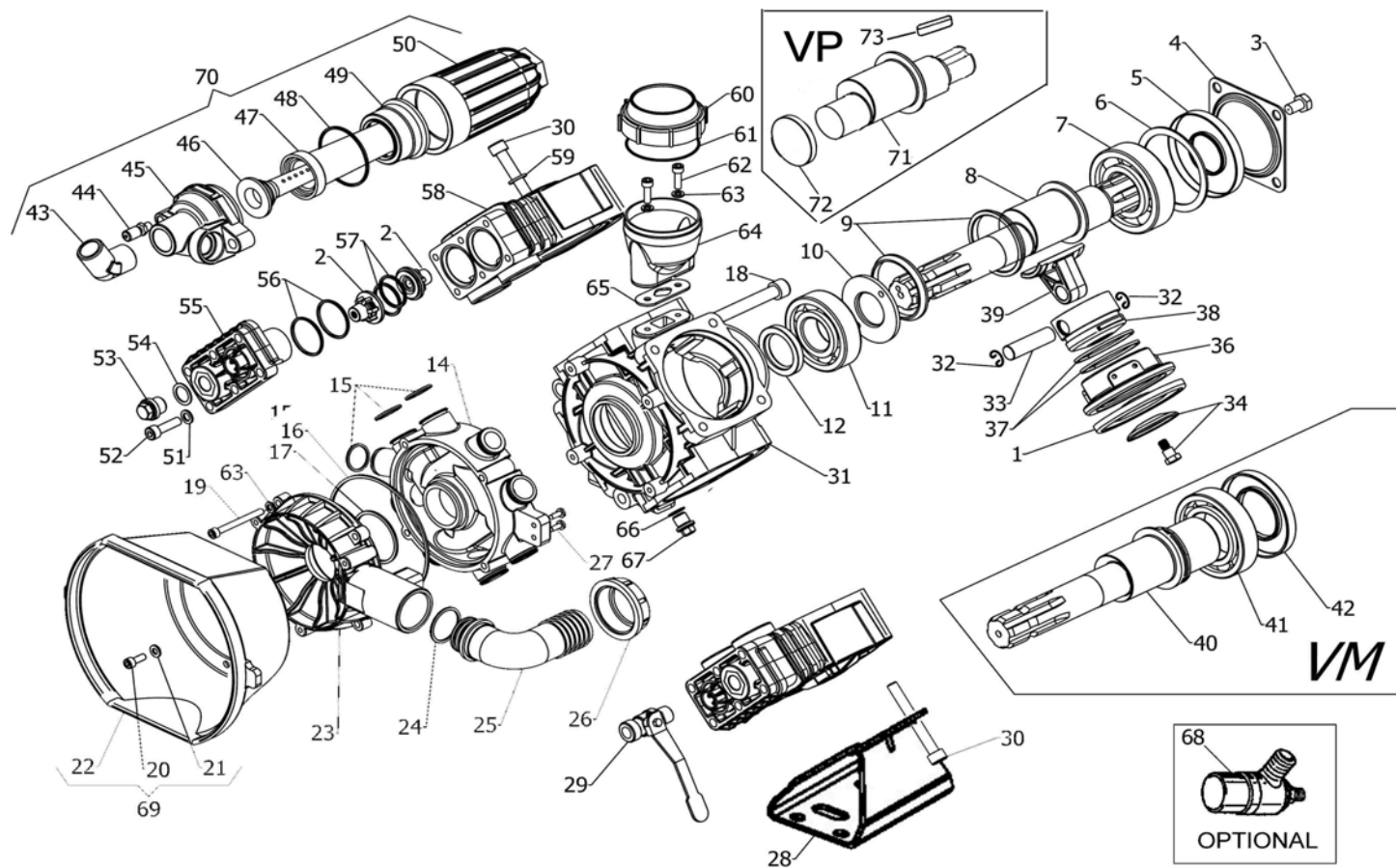

POS.	CODICE PART NO. REF.	DENOMINAZIONE - DESCRIPTION - DESCRIPTION	Q.TY	POS.	CODICE PART NO. REF.	DENOMINAZIONE - DESCRIPTION - DESCRIPTION	Q.TY
1	23.0011.31.2	PISTONS DIAPHRAGM BUNA-N	4	39	36.0015.11.2	CONROD	4
1	23.0011.33.2	PISTONS DIAPHRAGM VITON (OPT.)	4	40	36.0020.26.2	CRANSHAFT TYPE VM (1"3/8 M-F)	1
1	23.0011.00.2	PISTONS DIAPHRAGM DESMOPAN (OPT.)	4	41	81.2969.00.2	BALL BEARING 6210	1
2	23.9805.97.3	VALVE ASSY	8	42	80.2236.00.2	OIL SEAL 50X90X10	1
3	86.3187.00.2	SCREW M10X18 UNI5739	4	43	83.5063.28.2	60° ELBOW CONNECTOR G.3/4 M/M	1
4	17.0013.61.2	COVER	1	44	86.1605.00.2	AIR VALVE	1
5	80.2190.10.2	OIL SEAL 40X90X10	1	45	36.0010.28.2	BALLASTER BOARD	1
6	17.0024.76.2	PACKING SPACER	1	46	36.0013.32.2	INSIDE TUBE BALLASTER	1
7	81.2913.00.2	BEARING 45X90X23	1	47	36.0007.31.2	BALLASTER DIAPHRAGM	1
8	36.0017.26.2	CRANKSHAFT TYPE VD (1"3/8 M-M)	1	48	80.3210.00.2	O-RING DIA. 2.62X56,82	1
9	98.0047.76.2	CONROD RING	2	48	80.3210.10.2	O-RING DIA. 2.62X56,82 (KIT VITON)	1
10	36.0019.61.2	CONROD HOLDING RING	1	49	36.0014.09.2	DIAPHRAGM SPACER BALLASTER	1
11	81.2867.00.2	BEARING 35X80X21	1	50	36.0011.09.2	TOP BALLASTER	1
12	80.2143.10.2	OIL SEAL 35X52X7	1	51	84.3685.00.2	WASHER DIA. 8,2X15X1,5 UNI1750	24
14	36.0008.32.2	MANIFOLD	1	52	86.2730.00.2	SCREW TCEI M8X30 UNI5931	24
15	80.3204.00.2	O-RING DIA. 2.62X23,81	9	53	85.2579.00.2	CAP G.3/8	2
15	80.3204.50.2	O-RING DIA. 2.62X23,81	9	54	80.3065.00.2	O-RING DIA. D.1,78X14	2
16	80.3291.25.2	O-RING DIA. 3.53X123,4	1	54	80.3065.10.2	O-RING DIA. D.1,78X14 (KIT VITON)	2
16	80.3291.25.2	O-RING DIA. 3.53X123,4	1	55	36.0003.32.2	VALVE COVER	4
17	80.3270.00.2	O-RING DIA. 3.53X49,2	1	56	80.3208.30.2	O-RING DIA. 2.62X36,14	8
17	80.3270.50.2	O-RING DIA. 3.53X49,2 (KIT VITON)	1	56	80.3208.60.2	O-RING DIA. 2.62X36,14 (KIT VITON)	8
20	86.1846.00.2	SCREW TCTC 5.5x16 (OPTIONAL)	3	57	80.3207.00.2	O-RING DIA. 2.62X29,82	8
21	84.3560.00.2	WASHER DIA. 5,5x15x1,6 (OPTIONAL)	3	57	80.3207.50.2	O-RING DIA. 2.62X29,82 (KIT VITON)	8
22	31.1466.32.2	PLAIN SAFETY CONE (OPTIONAL)	1	58	36.0002.09.2	HEAD	4
23	36.0009.32.2	MANIFOLD COVER	1	59	84.3801.00.2	WASHER DIA. 10,5X18X2 UNI1750	8
24	80.3219.10.2	O-RING DIA. 3,0X30	1	60	28.0144.32.2	FILLER COVER	1
25	84.0591.00.2	90° ELBOW CONNECTOR DIA. 40-1,57"	1	61	80.3109.20.2	O-RING DIA. 1,8X67	1
26	82.0070.00.2	WING NUT G.1"1/2	1	62	86.2166.00.2	SCREW TCEI M6X20 UNI5931	2
27	86.1843.00.2	SCREW D.4.8X16	2	63	84.3585.00.2	WASHER DIA. 6 UNI6592	6
28	36.0033.61.2	FOOT	2	64	14.0012.32.2	OIL FILLER	1
29	84.5544.10.2	LEFT TAP	2	65	14.0017.72.2	OIL FILLER GASKET	1
30	86.3590.00.2	SCREW TCEI M10X80 UNI5931	16	66	82.4079.00.2	GASKET D.13,2X17X1	1
31	36.0001.09.2	CRANKCASE	1	67	85.2543.50.2	CAP G.1/4X9	1
32	80.0021.00.2	SNAP RING	8	68	24.3040.97.3	SECURITY VALVE 40 BAR(OPTIONAL)	1
33	85.2007.00.2	PISTON PIN 15 X 54	4	69	36.9814.97.3	PLAIN SAFETY CONE KIT	1
34	23.0055.97.3	KIT DISK INOX+SCREW	4	70	36.9810.97.3	BALLASTER KIT	1
36	23.0038.01.2	PISTONS SLEEVE	4	71	36.0034.26.2	CRANKSHAFT TYPE "VP" (D.35 M)	1
37	81.8514.00.2	PISTONS RING DIA .62X2,5	8	72	80.2092.20.2	CAP	1
38	23.0040.09.2	PISTONS DIA .62	4	73	80.6580.20.2	TAB 10X8X50 UNI 6604	1